

PNOZ ma1p

PILZ
THE SPIRIT OF SAFETY

- ▶ Configurable safety systems PNOZmulti

This document is a translation of the original document.

All rights to this documentation are reserved by Pilz GmbH & Co. KG. Copies may be made for internal purposes. Suggestions and comments for improving this documentation will be gratefully received.

Source code from third-party manufacturers or open source software has been used for some components. The relevant licence information is available on the Internet on the Pilz homepage.

Pilz®, PIT®, PMI®, PNOZ®, Primo®, PSEN®, PSS®, PVIS®, SafetyBUS p®, SafetyEYE®, SafetyNET p®, the spirit of safety® are registered and protected trademarks of Pilz GmbH & Co. KG in some countries.



SD means Secure Digital

Section 1	Introduction	4
	1.1 Validity of documentation	4
	1.2 Using the documentation	4
	1.3 Definition of symbols	4
Section 2	Overview	6
	2.1 Scope	6
	2.2 Unit features	6
	2.3 Front view	7
Section 3	Safety	8
	3.1 Intended use	8
	3.2 System requirements	8
	3.3 Safety regulations	9
	3.3.1 Safety assessment	9
	3.3.2 Use of qualified personnel	9
	3.3.3 Warranty and liability	9
	3.3.4 Disposal	9
	3.3.5 For your safety	10
Section 4	Function Description	11
	4.1 Integrated protection mechanisms	11
	4.2 Functions	12
	4.3 Block diagram	13
Section 5	Installation	14
	5.1 General installation guidelines	14
	5.2 Dimensions	14
	5.3 Connecting the base unit and expansion modules	15
Section 6	Commissioning	16
	6.1 Wiring	16
	6.2 Download modified project to the PNOZmulti system	16
	6.3 Connection	17
Section 7	Operation	18
	7.1 LED indicators	18
Section 8	Technical details	19
	8.1 Safety characteristic data	22
Section 9	Order reference	23
	9.1 Product	23
	9.2 Accessories	23

1 Introduction

1.1 Validity of documentation

This documentation is valid for the product PNOZ ma1p. It is valid until new documentation is published.

This operating manual explains the function and operation, describes the installation and provides guidelines on how to connect the product.

1.2 Using the documentation

This document is intended for instruction. Only install and commission the product if you have read and understood this document. The document should be retained for future reference.

1.3 Definition of symbols

Information that is particularly important is identified as follows:



DANGER!

This warning must be heeded! It warns of a hazardous situation that poses an immediate threat of serious injury and death and indicates preventive measures that can be taken.



WARNING!

This warning must be heeded! It warns of a hazardous situation that could lead to serious injury and death and indicates preventive measures that can be taken.



CAUTION!

This refers to a hazard that can lead to a less serious or minor injury plus material damage, and also provides information on preventive measures that can be taken.



NOTICE

This describes a situation in which the product or devices could be damaged and also provides information on preventive measures that can be taken. It also highlights areas within the text that are of particular importance.

**INFORMATION**

This gives advice on applications and provides information on special features.

2 Overview

2.1 Scope

- ▶ Expansion module PNOZ ma1p
- ▶ Jumper

2.2 Unit features

Using the product PNOZ ma1p:

Expansion module for connection to a base unit from the configurable control system PNOZmulti

The product has the following features:

- ▶ 2 safe analogue inputs for current or voltage measurement
- ▶ Each input can be configured separately
- ▶ Voltage range: -10,24 ... +10.2375 V
- ▶ Current range: 0 ... 25.59 mA
- ▶ Resolution
 - Voltage measurement: 13 Bit (signed 12 Bit)
 - Current measurement: 12 Bit
- ▶ Range monitoring to monitor for wiring errors or errors in the sensor (4 range limits can be configured)
- ▶ Threshold value monitoring to monitor process variables (8 threshold values can be configured)
- ▶ Max. 4 PNOZ ma1p units can be connected to the base unit
- ▶ Exact analogue value can be passed to a fieldbus for diagnostic purposes
- ▶ LEDs for
 - Operating state
 - State of the input signals (Ch0, Ch1)
 - Error
- ▶ Coated version:
Increased environmental requirements (see [Technical details](#)  19)
- ▶ Plug-in connection terminals:
either spring-loaded terminal or screw terminal available as an accessory (see order reference)
- ▶ Please refer to the document "PNOZmulti System Expansion" for the PNOZmulti base units that can be connected.

2.3 Front view

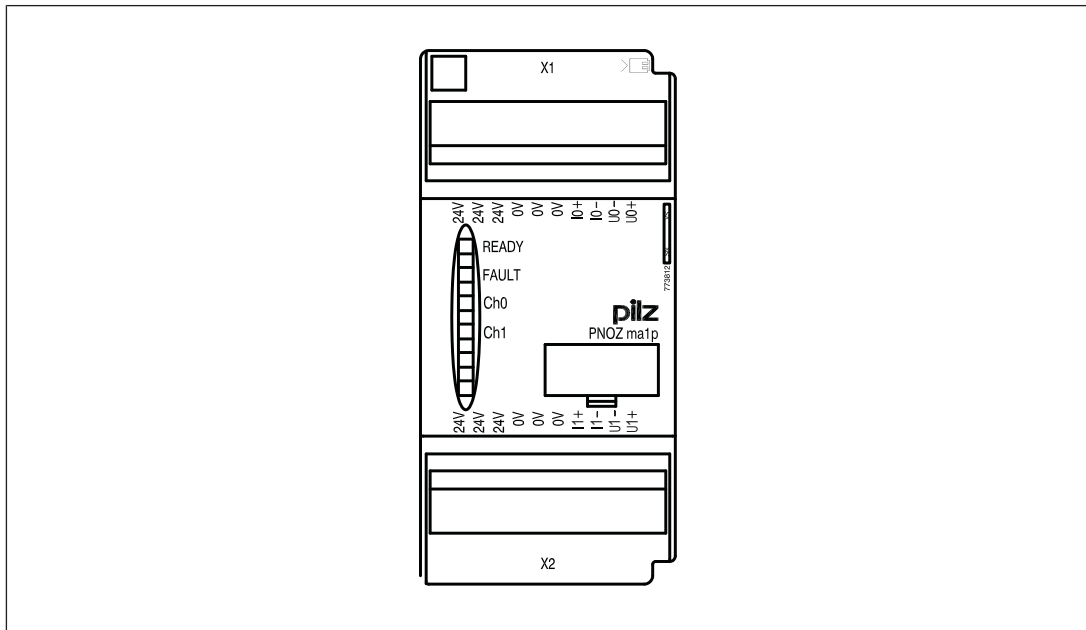

Key:

- ▶ 0 V, 24 V:
Supply connections
- ▶ I0+, I0-:
Inputs for current measurement
- ▶ U0+, U0-:
Inputs for voltage measurement

3 Safety

3.1 Intended use

The expansion module is an analogue input module. It provides 2 safe analogue inputs for current or voltage measurement. For current measurement, both inputs can be used independently. For voltage measurement, both inputs must always be wired. The analogue inputs are suitable for connecting transducers or input devices with standardised 10 V voltage signals or 20 mA current signals. The analogue inputs are designed as differential inputs. Each analogue input has a signal range of –10 VDC to +10 VDC or 0 mA to 25 mA.

The expansion module may only be connected to a base unit from the PNOZmulti system (please refer to the document "PNOZmulti System Expansion" for details of the base units that can be connected).

The configurable small control systems PNOZmulti are used for the safety-related interruption of safety circuits and are designed for use in:

- ▶ E-STOP equipment
- ▶ Safety circuits in accordance with VDE 0113 Part 1 and EN 60204-1

The following is deemed improper use in particular:

- ▶ Any component, technical or electrical modification to the product
- ▶ Use of the product outside the areas described in this manual
- ▶ Use of the product outside the technical details (see [Technical details](#) [ 19]).



NOTICE

EMC-compliant electrical installation

The product is designed for use in an industrial environment. The product may cause interference if installed in other environments. If installed in other environments, measures should be taken to comply with the applicable standards and directives for the respective installation site with regard to interference.

The coated version of the product PNOZ ma1p is suitable for use where there are increased environmental requirements (see [Technical details](#) [ 19]).

3.2 System requirements

Please refer to the "Product Modifications PNOZmulti" document in the "Version overview" section for details of which versions of the base unit and PNOZmulti Configurator can be used for this product.

3.3 Safety regulations

3.3.1 Safety assessment

Before using a unit it is necessary to perform a safety assessment in accordance with the Machinery Directive.

Functional safety is guaranteed for the product as a single component. However, this does not guarantee the functional safety of the overall plant/machine. In order to achieve the required safety level for the overall plant/machine, define the safety requirements for the plant/machine and then define how these must be implemented from a technical and organisational standpoint.

3.3.2 Use of qualified personnel

The products may only be assembled, installed, programmed, commissioned, operated, maintained and decommissioned by competent persons.

A competent person is someone who, because of their training, experience and current professional activity, has the specialist knowledge required to test, assess and operate the work equipment, devices, systems, plant and machinery in accordance with the general standards and guidelines for safety technology.

It is the company's responsibility only to employ personnel who:

- ▶ Are familiar with the basic regulations concerning health and safety / accident prevention
- ▶ Have read and understood the information provided in this description under "Safety"
- ▶ And have a good knowledge of the generic and specialist standards applicable to the specific application.

3.3.3 Warranty and liability

All claims to warranty and liability will be rendered invalid if

- ▶ The product was used contrary to the purpose for which it is intended
- ▶ Damage can be attributed to not having followed the guidelines in the manual
- ▶ Operating personnel are not suitably qualified
- ▶ Any type of modification has been made (e.g. exchanging components on the PCB boards, soldering work etc.).

3.3.4 Disposal

- ▶ In safety-related applications, please comply with the mission time T_M in the safety-related characteristic data.
- ▶ When decommissioning, please comply with local regulations regarding the disposal of electronic devices (e.g. Electrical and Electronic Equipment Act).

3.3.5 For your safety

The unit meets all the necessary conditions for safe operation. However, you should always ensure that the following safety requirements are met:

- ▶ This operating manual only describes the basic functions of the unit. The expanded functions are described in the PNOZmulti Configurator's online help. Only use these functions once you have read and understood the documentations.
- ▶ Do not open the housing or make any unauthorised modifications.
- ▶ Please make sure you shut down the supply voltage when performing maintenance work (e.g. exchanging contactors).

4 Function Description

4.1 Integrated protection mechanisms

The relay conforms to the following safety criteria:

- ▶ The circuit is redundant with built-in self-monitoring.
- ▶ The safety function remains effective in the case of a component failure.

The analogue input module can be used for applications up to SIL3.

For applications in accordance with SIL2 or SIL3, input devices must be attached that are certified for SIL2 in accordance with IEC 61508. The output signal of the input device must be monitored, i.e. actual and set value must be compared with one another. In the event of a deviation, a reaction must occur that the PNOZmulti recognises and to which it reacts.

▶ **SIL2 applications:**

SIL2 applications are **only possible for current measurement**. If the analogue input module is to be used for current measurement on SIL2 applications, both inputs can be used independently for current measurement.

▶ **SIL3 applications:**

If the analogue input module is to be used for SIL3 applications, both inputs must be configured. They will then be combined to form a SIL3 input. To do this, connect a suitable encoder to each input. The analogue input module will then check the feasibility of the input signals, i.e. the values measured from both input signals are compared.



NOTICE

For SIL3 applications, set a maximum permitted deviation between the measured values of both input signals (tolerance) in the PNOZmulti Configurator. A tolerance is only entered to balance out the imprecision of the signal recording, the encoder and the analogue input module. To maintain safety, the tolerance should be set as low as possible. Please note that the **maximum safety-related measurement error for the overall system** is composed of the following measurement errors:

Error during signal recording

+ Sensor measurement error

+ Max. measurement error in the event of a potential module error

To ensure that your application switches off safely in the event of a critical process variable, the configuration of the range limits/threshold values must be increased/decreased to take into account the maximum measurement error.

**NOTICE**

When using the analogue input module for voltage measurement, please note the following:

If the input signal is open circuit or there is a short circuit, this will not be detected with an input voltage of 0 V. Please use your risk assessment/hazard analysis to check whether your application fulfills the safety-related requirements or whether additional measures must be taken. We recommend that you configure a permitted value range between 2 - 10 V PNOZmulti Configurator.

4.2

Functions

The analogue input module monitors analogue input signals. It can measure both current and voltage.

The input signals are collected and read in at each input through two channels and are converted into digital signals. The resolution is 13 Bit for voltage measurement, 12 Bit for current measurement.

In the PNOZmulti Configurator you can define limit values, which are to be monitored:

▶ **Range monitoring**

With range monitoring you can define the permitted value range. You can define up to 4 range limits (e.g. <3 mA monitored for open circuit; $I > 21$ mA monitored for encoder error). Depending on the selected condition ("greater than" or "less than"), the ENBL output bit and output bits 1 - 8 for threshold value monitoring are set to "0" if the recorded value exceeds or drops below a range limit. An entry is added to the error stack.

Exception: If "automatic start" type has been selected, no entry will be added to the error stack.

▶ **Threshold value monitoring**

You can define up to 8 switching thresholds, which can be used to monitor certain process variables (e.g. different temperature values). The thresholds can be configured with or without scaling. 2 threshold values are configured per threshold. One threshold value defines when the relevant output bit (1 ... 8) is set to "1". The second threshold value defines when the output bit is reset to "0". No entry is added to the error stack.

The **exact analogue values** are made available to the base unit to forward to a fieldbus. This value is transmitted through a single channel and is not safety-related. It can be used for diagnostic purposes.

**INFORMATION**

The online help on the PNOZmulti Configurator contains descriptions of the operating modes and all the functions of the control system PNOZmulti.

4.3 Block diagram

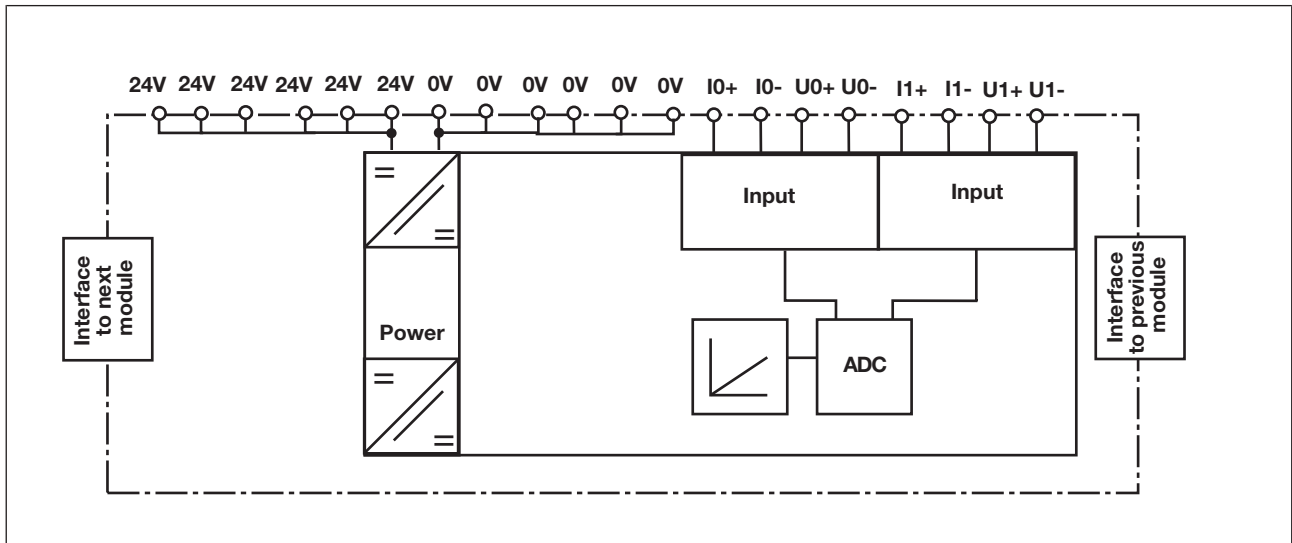

5 Installation

5.1 General installation guidelines

- ▶ The control system should be installed in a control cabinet with a protection type of at least IP54. Fit the control system to a horizontal mounting rail. The venting slots must face upward and downward. Other mounting positions could destroy the control system.
- ▶ Use the notches on the rear of the unit to attach it to a mounting rail. Connect the control system to the mounting rail in an upright position, so that the earthing springs on the control system are pressed on to the mounting rail.
- ▶ The ambient temperature of the PNOZmulti units in the control cabinet must not exceed the figure stated in the technical details, otherwise air conditioning will be required.
- ▶ To comply with EMC requirements, the mounting rail must have a low impedance connection to the control cabinet housing.



CAUTION!

Damage due to electrostatic discharge!

Electrostatic discharge can damage components. Ensure against discharge before touching the product, e.g. by touching an earthed, conductive surface or by wearing an earthed armband.

5.2 Dimensions

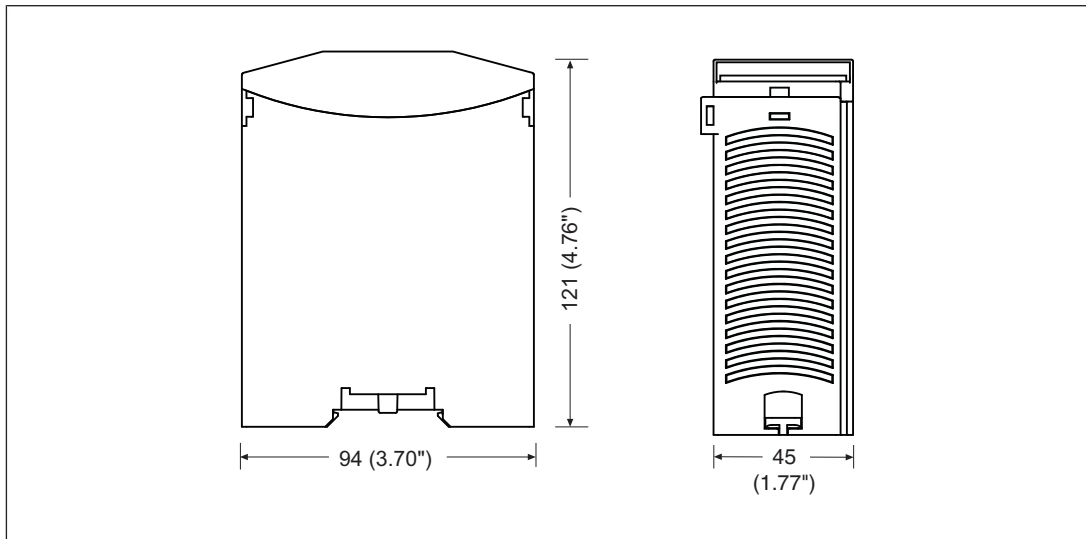

5.3 Connecting the base unit and expansion modules

Connect the base unit and the expansion module as described in the operating instructions for the base units.

- ▶ Do **not** connect a terminator to the last expansion module on the left-hand side.
- ▶ Install the expansion module in the position in which it is configured in the PNOZmulti Configurator.

The position of the expansion modules is defined in the PNOZmulti Configurator. The expansion modules are connected to the left or right of the base unit, depending on the type.

Please refer to the document "PNOZmulti System Expansion" for details of the number of modules that can be connected to the base unit and the module types.

6 Commissioning

6.1 Wiring

The wiring is defined in the circuit diagram of the PNOZmulti Configurator.

Please note:

- ▶ Information given in the [Technical details](#) [ 19] must be followed.
- ▶ Use copper wire that can withstand 75° C.
- ▶ The power supply that feeds the expansion module and the input devices must meet the regulations for extra low voltages with protective separation (SELV, PELV).
- ▶ 6 connection terminals are available for each of the supply connections 24 V and 0 V. This means that the supply voltage can be looped through several connections and the encoder can be supplied.
- ▶ Use shielded, twisted pair cable for the connections on the input current circuits.
- ▶ Separate the supply voltage cable from the analogue input current lines.
- ▶ If the analogue input module is used to measure current, the voltage inputs must be short-circuited.
- ▶ **For transducers located outside the control cabinet:** Where the cable enters the control cabinet, the cable shield **must** be connected to the earth potential over a wide surface area and with low impedance (connect in star).



NOTICE

If the analogue input module is used to measure voltage, both inputs must be wired.

6.2 Download modified project to the PNOZmulti system

As soon as an additional expansion module has been connected to the system, the project must be amended using the PNOZmulti Configurator. Proceed as described in the operating instructions for the base unit.



NOTICE

For the commissioning and after every program change, you must check whether the safety devices are functioning correctly.

6.3 Connection

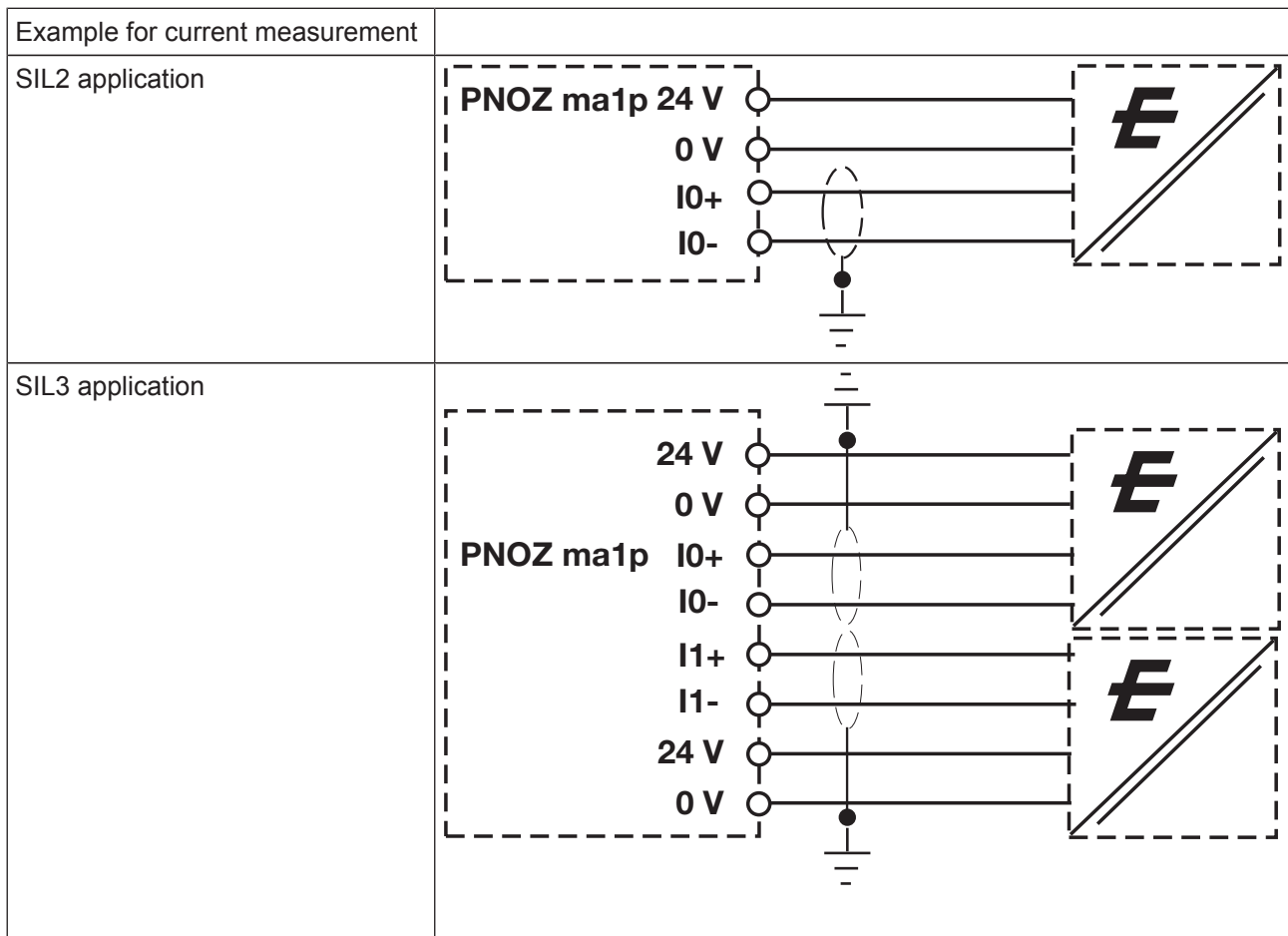

Connection to transducer (SIL2 or SIL3)

Please note:

- ▶ The transducers are SIL2 certified
- ▶ The voltage supply to the input device is optional
- ▶ With current measurement, the voltage inputs U+ - U- must be short-circuited.



CAUTION!

A constant load of $\pm 15\text{ V}$ or $\pm 50\text{ mA}$ per input must not be exceeded under any circumstances

7 Operation



When the supply voltage is switched on, the PNOZmulti safety system copies the configuration from the chip card.











The LEDs "POWER", "DIAG", "FAULT", "IFAUULT" and "OFAULT" will light up on the base unit.

The PNOZmulti safety system is ready for operation when the "POWER" and "RUN" LEDs on the base unit and the "READY" LED on the PNOZ ma1p are lit continuously.

7.1 LED indicators

Legend

-  LED on
-  LED flashes
-  LED off

LED	LED status		Meaning
READY		Green	The unit is ready for operation
			The unit is not ready for operation
FAULT		Red	External error
		Red	Internal error
			No fault
CH0		Red	Value at I0 has fallen below the lower range limit
		Red	Upper threshold value at I0 exceeded; with SIL3 (Ch0 and Ch1 flashing alternately): set tolerance exceeded
		Green	Measuring range at I0 within the defined range
CH1		Red	Value at I1 has fallen below the lower range limit
		Red	Upper threshold value at I1 exceeded; with SIL3 (Ch0 and Ch1 flashing alternately): set tolerance exceeded
		Green	Measuring range at I1 within the defined range

8 Technical details

General	773812	773813
Approvals	BG, CCC, CE, EAC (Eurasian), TÜV, cULus Listed	BG, CCC, CE, EAC (Eurasian), TÜV, cULus Listed
Electrical data	773812	773813
Supply voltage		
for	Module supply	Module supply
Voltage	24,0 V	24,0 V
Kind	DC	DC
Voltage tolerance	-15 %/+20 %	-15 %/+20 %
Output of external power supply (DC)	2,0 W	2,0 W
Residual ripple DC	5 %	5 %
Status indicator	LED	LED
Analogue inputs	773812	773813
Number of analogue inputs	2	2
Type of analogue inputs	Voltage, current	Voltage, current
Input filter	1st order, RC filter	1st order, RC filter
Cutoff frequency	80 Hz	80 Hz
Current measurement		
Signal range	0,00 - 25,59 mA	0,00 - 25,59 mA
Value range	0 - 4095 d	0 - 4095 d
Resolution	12 Bit	12 Bit
Value of least significant bit (LSB)	6,25 µA	6,25 µA
Input resistance	100,000 Ohm	100,000 Ohm
Max. continuous current	50 mA	50 mA
Voltage measurement		
Signal range	-10,2400 - 10,2375 V	-10,2400 - 10,2375 V
Value range	-4096 - 4095 d	-4096 - 4095 d
Resolution	13 Bit (signed 12 Bit)	13 Bit (signed 12 Bit)
Value of least significant bit (LSB)	5 mV	5 mV
Input resistance	290 kOhm	290 kOhm
Max. continuous voltage	-30 - 30 V	-30 - 30 V
Deviations from the measuring range limit value		
Output variable error at 25 °C	0,5 %	0,5 %
Temperature coefficient	0,0025 %/K	0,0025 %/K
Greatest transient deviation during el. interference test	1,0 %	1,0 %
Max. measurement error at full temperature range	0,5 %	0,5 %
Max. measurement error in the case of a potential module error	1,5 %	1,5 %

Analogue inputs	773812	773813
Max. voltage between inputs I0 and I1 with current or voltage measurement	30 V	30 V
Filter time constant	2,0 ms	2,0 ms
Potential isolation	No	No
Times	773812	773813
Switch-on delay	5,00 s	5,00 s
Supply interruption before de-energisation	20 ms	20 ms
Max. reaction time when the input signal changes	100 ms	100 ms
Environmental data	773812	773813
Ambient temperature		
In accordance with the standard	EN 60068-2-14	EN 60068-2-14
Temperature range	0 - 60 °C	-25 - 60 °C
Forced convection in control cabinet off	55 °C	55 °C
Storage temperature		
In accordance with the standard	EN 60068-2-1/-2	EN 60068-2-1/-2
Temperature range	-25 - 70 °C	-25 - 70 °C
Climatic suitability		
In accordance with the standard	EN 60068-2-30, EN 60068-2-78	EN 60068-2-30, EN 60068-2-78
Humidity	93 % r. h. at 40 °C	93 % r. h. at 40 °C
Condensation during operation	Not permitted	Short-term
EMC	EN 61131-2	EN 61131-2
Vibration		
In accordance with the standard	EN 60068-2-6	EN 60068-2-6
Frequency	10,0 - 150,0 Hz	–
Acceleration	1g	1g
Broadband noise		
In accordance with the standard	–	EN 60068-2-64
Frequency	–	5 - 500 Hz
Acceleration	–	1,9grms
Shock stress		
In accordance with the standard	EN 60068-2-27	EN 60068-2-27
Acceleration	15g	15g
Duration	11 ms	11 ms
Max. operating height above sea level	2000 m	2000 m
Airgap creepage		
In accordance with the standard	EN 61131-2	EN 61131-2
Overvoltage category	III	III
Pollution degree	2	2
Rated insulation voltage	30 V	30 V

Environmental data	773812	773813
Protection type		
In accordance with the standard	EN 60529	EN 60529
Mounting area (e.g. control cabinet)	IP54	IP54
Housing	IP20	IP20
Terminals	IP20	IP20
Mechanical data	773812	773813
Mounting position	Horizontal on top hat rail	Horizontal on top hat rail
DIN rail		
Top hat rail	35 x 7,5 EN 50022	35 x 7,5 EN 50022
Recess width	27 mm	27 mm
Material		
Bottom	PPO UL 94 V0	PPO UL 94 V0
Front	ABS UL 94 V0	ABS UL 94 V0
Connection type	Spring-loaded terminal, screw terminal	Spring-loaded terminal, screw terminal
Conductor cross section with screw terminals		
1 core flexible	0,25 - 1,50 mm², 24 - 16 AWG	0,25 - 1,50 mm², 24 - 16 AWG
2 core with the same cross section, flexible without crimp connectors or with TWIN crimp connectors	0,25 - 0,75 mm², 24 - 20 AWG	0,25 - 0,75 mm², 24 - 20 AWG
Torque setting with screw terminals	0,25 Nm	0,25 Nm
Stripping length with screw terminals	7 mm	7 mm
Conductor cross section with spring-loaded terminals		
1 core flexible without crimp connector	0,25 - 1,50 mm², 24 - 16 AWG	0,25 - 1,50 mm², 24 - 16 AWG
1 core flexible with crimp connector	0,25 - 0,75 mm², 24 - 20 AWG	0,25 - 0,75 mm², 24 - 20 AWG
Spring-loaded terminals: Terminal points per connection	1	1
Stripping length with spring-loaded terminals	9,0 mm	9,0 mm
Dimensions		
Height	94,0 mm	94,0 mm
Width	45,0 mm	45,0 mm
Depth	121,0 mm	121,0 mm
Weight	184 g	196 g

Where standards are undated, the 2009-10 latest editions shall apply.

8.1 Safety characteristic data



NOTICE

You must comply with the safety-related characteristic data in order to achieve the required safety level for your plant/machine.

Operating mode	EN ISO 13849-1: 2008 PL	EN ISO 13849-1: 2008 Category	EN 62061 SIL CL	EN 62061 PFH _D [1/h]	IEC 61511 SIL	IEC 61511 PFD	EN ISO 13849-1: 2008 T _M [year]
1-channel	PL e	Cat. 4	SIL CL 3	8,71E-09	SIL 3	4,21E-05	20
2-channel	PL e	Cat. 4	SIL CL 3	8,71E-09	SIL 3	4,21E-05	20

All the units used within a safety function must be considered when calculating the safety characteristic data.



INFORMATION

A safety function's SIL/PL values are **not** identical to the SIL/PL values of the units that are used and may be different. We recommend that you use the PAscal software tool to calculate the safety function's SIL/PL values.

9 Order reference

9.1 Product

Product type	Features	Order No.
PNOZ ma1p	Expansion module, 2 analogue inputs	773 812
PNOZ ma1p coated version	Expansion module, 2 analogue inputs, coated version	773 813

9.2 Accessories

Connection terminals

Product type	Features	Order No.
Set spring terminals	1 set of spring-loaded terminals	783 700
Set screw terminals	1 set of screw terminals	793 700

Terminator, jumper

Product type	Features	Order No.
PNOZmulti bus terminator	Terminator	779 110
PNOZmulti bus terminator coated	Terminator, coated version	779 112
KOP-XE	Jumper	774 639
KOP-XE coated	Jumper, coated version	774 640